

# Metco A150-40-TD

## Ultra High Pressure Pump

## Features and Benefits

The Jetstream Pump fluid end has best in class serviceability. With components that can be accessed easily. The pump can be safely rotated by hand, to service packings.

- In high ambient temperatures, engines can de-rate which will result in decreased output from the pump. The Metco pump set can maintain performance in high ambient temperatures. Fitted with a Cummins QSB 150hp low emission Diesel engine, full pump capacity is ensured even on a hot day where others may struggle.
- Jetstream 3000 pump can tolerate hotter water than its competitors due to its robust design and high inlet charge pressure. Paired with Metco's control system grants a greatly improved service life.
- Common rail engines demand clean fuel to avoid costly repairs. All Metco pumps use Diesel fuel spec high-density polyethylene (marine spec) fuel tanks. These tanks will never suffer from rust, acid corrosion or fatigue cracking like steel or aluminium.
- The trailer skid frame is extremely ridged and flex free. This ensures long life from the pump drive coupling and exhibits no alarming vibration problems that may be experienced with other pump sets. Greatly reducing the risk of component failing.
- With easy access to all serviceable engine and pump components. In the event of major service work.



*Robust design built to withstand high demand*

15K PSI,  
20K PSI  
&  
40K PSI  
Models  
available

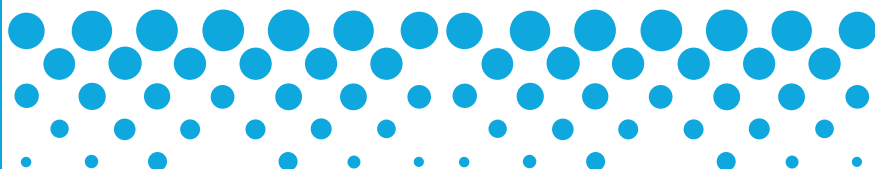

## Specifications

- Cummins fuel efficient QSB 150hp low emission 4.5L Tier 3 Diesel engine. 50 degree H/duty (high trash) cooling package.
- Jetstream 3000 series Pressure pump available in 15K, 20K and 40K PSI.
- Hot dipped fully galvanised high strength low vibration chassis.
- Anti Vibration skid mounts
- 250L fuel tank mounted in steel bund.
- Heat wrapped exhaust system and turbo.
- Plunger cooling water recovery system.
- Remote E-stop
- Electronic control system with live feedback of engine/pump settings and alarms. Touch Screen and buttons for operaton when warning gloves.
- Pump tilt monitoring.
- Pump oil level protection.
- Water level and over pressure protection.
- 3.5 T hitch, bluetooth break away system
- Load share low access suspension with 12" electric brake and park brake
- Front and rear fire extinguishers
- 4 x Corner wind up props

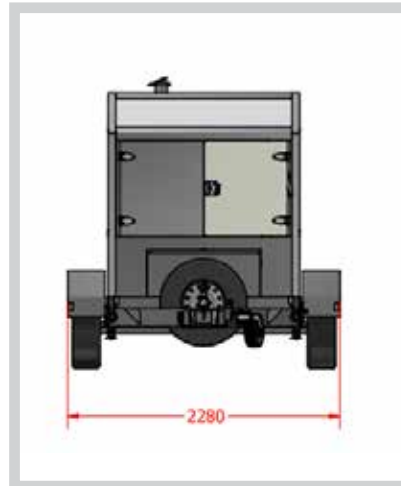
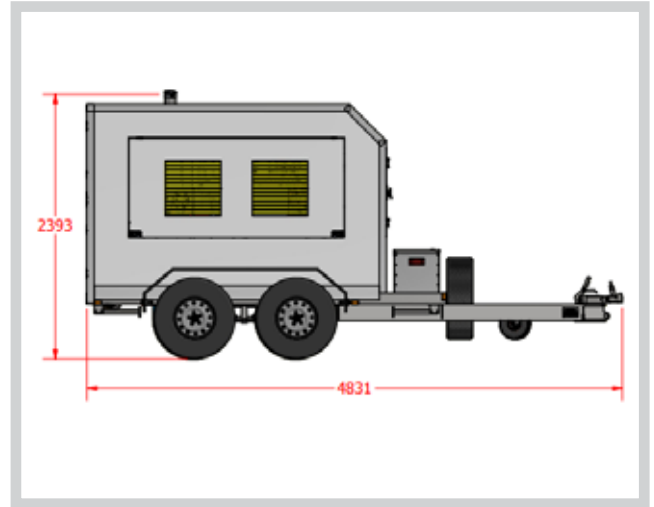

Pump fluid end has best in class serviceability.

Easy access to service engine and pump

## Performance

### Jetstream 3000 Series - 15 K, 20K, 40 PSI Options

# 11 Plungers	10,000Psi (689 bar & 88 lpm)
# 9 Plungers	15,000Psi (1034 bar & 56 lpm)
# 8 Plungers	20,000Psi (1380 bar & 42 lpm)
# 5 Plungers	40,000Psi (2750 bar & 19.5 lpm)

### Cummins QSB 150hp Low emission tier 3 Diesel engine

Trailer skid mass	~3200 Kg*
Fuel tank internal volume	~250 Lt
Charge pump	25–40Psi

\*No fuel or water

Powered by



**DISCLAIMER:** All images are a representation only and are not to scale. Although care has been taken to ensure the accuracy, completeness and reliability of the information provided, due to ongoing product development and improvements, products may vary from this data sheet. The user of the information agrees that the information is subject to change without notice.